

Falsing problems with After-Market Alarms on select Ford's

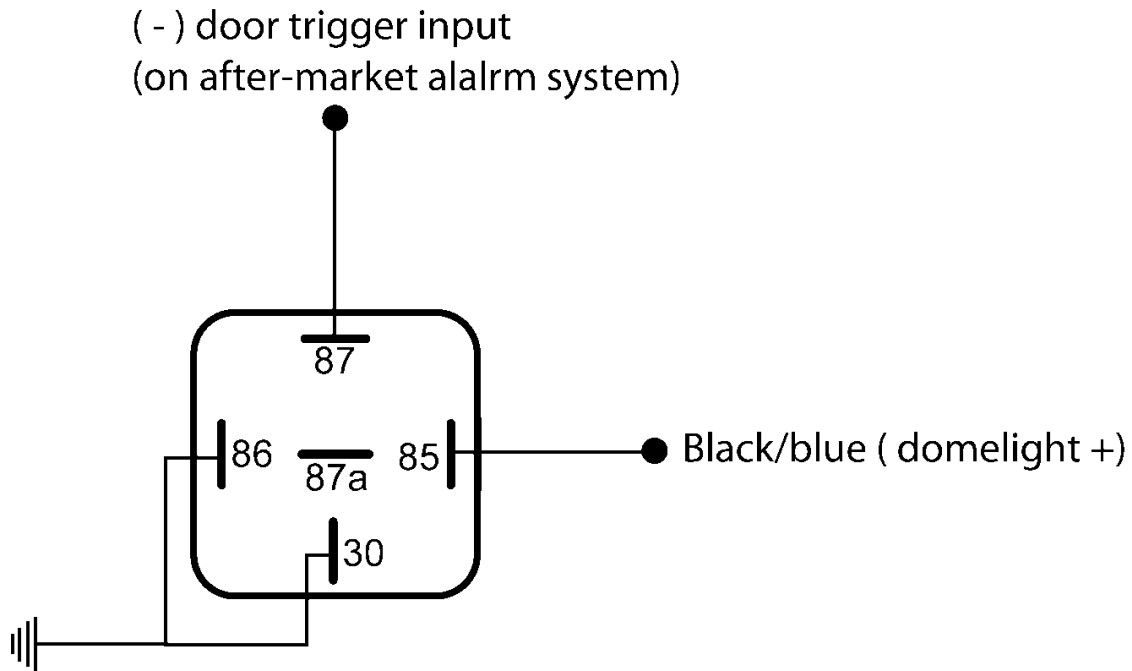

On some Ford's, there is a problem with false alarms when an after-market alarm is installed and connected to the Dome-light wire for door supervision. This is caused by diagnostic pulses send down the wire by the vehicle's GEM module. The solution is to add a relay. This will isolate these pulses yet still allow the dome-light to be used for door supervision.

NOTE: The information on this sheet is provided on an "as is" basis with no representation or warranty of accuracy whatsoever. It is the sole responsibility of the installer to check and verify any circuit before connecting to it. Only a computer safe logic probe or digital multimeter should be used. Wiremagic.com Corp. assumes absolutely no liability or responsibility whatsoever pertaining to the accuracy or currency of the information supplied. The installation in every case is the sole responsibility of the installer performing the work and Wiremagic.com Corp. assumes no liability or responsibility whatsoever resulting from any type of installation, whether performed properly, improperly or any other way. The information supplied is a guide only.