

1999+ WINDSTAR PARKING LIGHTS INTERFACE

Without Auto Headlights

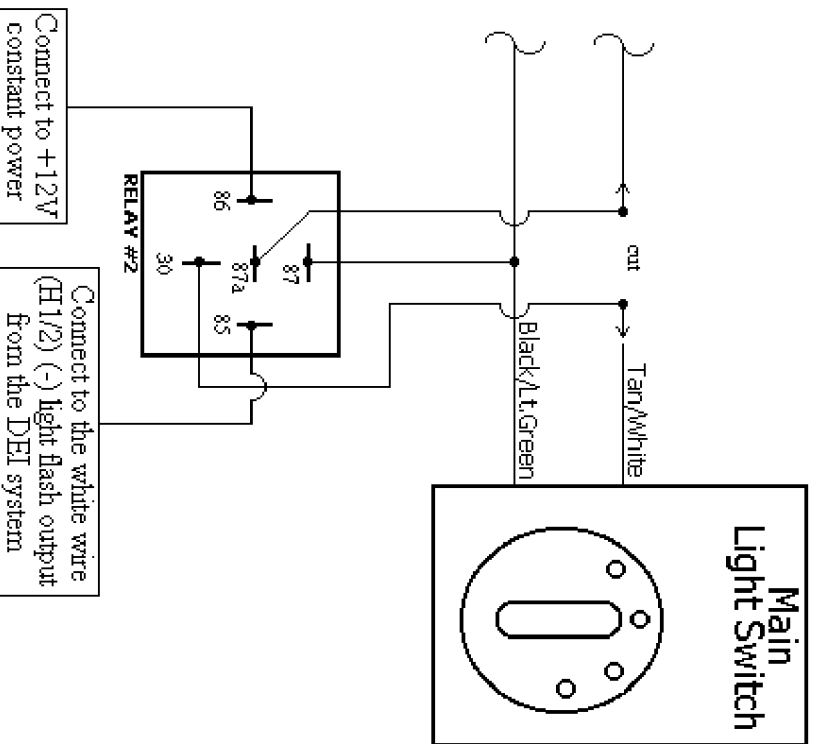

With Auto Headlights

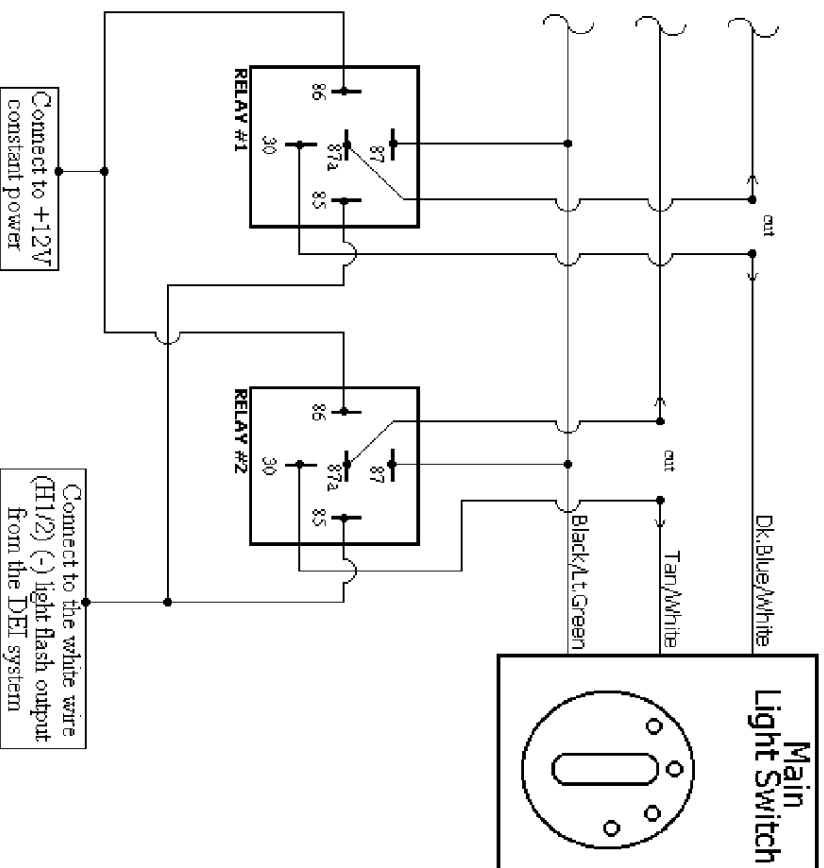

IMPORTANT!
 This wiring information is being provided free of charge on an "as is" basis, without any representation or warranty. It is the dealers responsibility to verify any circuit before interfacing with it using a digital multimeter. Directed Electronics Inc. assumes no responsibility with regards to the accuracy or content of this information. Proper installation in every case remains the responsibility of the installer. DEI assumes no liability or responsibility resulting from an improper installation. Even in reliance on this information.