

1996-2000 Town and Country, Caravan, and Voyager

Factory Disarm for Remote Start

When adding a remote start to these vans that come equipped with factory security, you must disarm the security prior to remote start. To do this you will need to pulse the unlock wire first and then pulse the lock wire to re-lock the doors. This can be accomplished by following the diagram below. Make sure to add a **diode** on the wire that ties into the **Violet** wire on the ribbon harness or the car will crank the starter while locking the doors with the remote control.

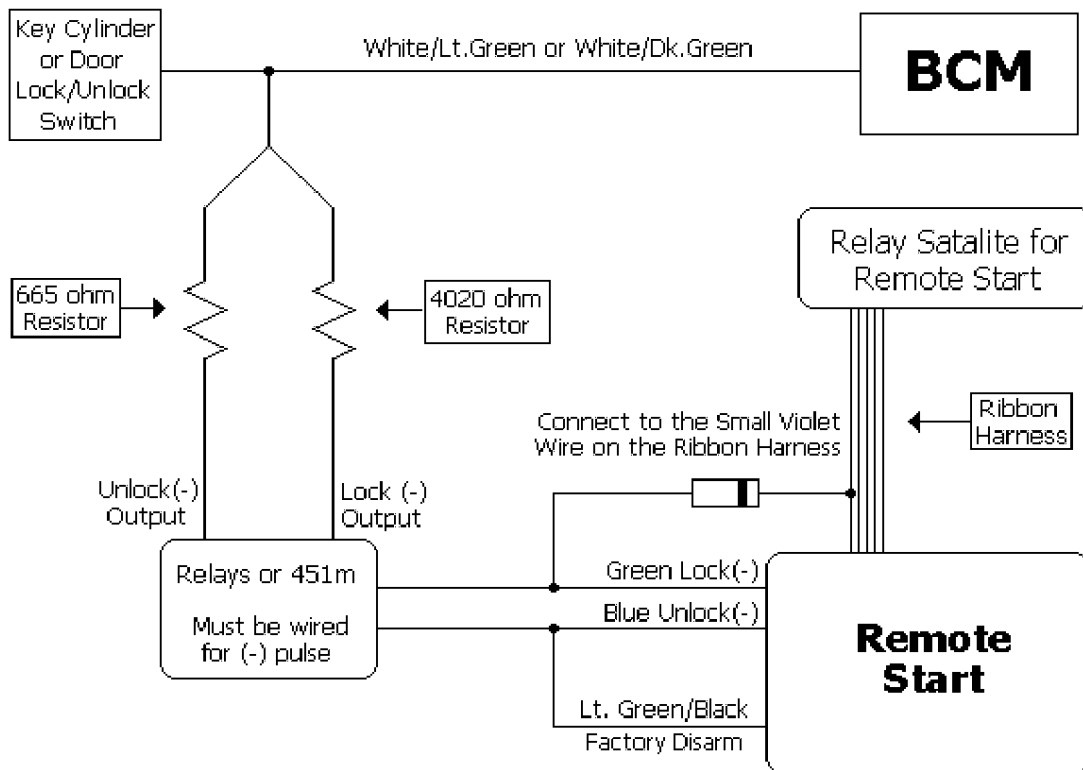

IMPORTANT: This wiring information is being provided free of charge on an “as is” basis, without any representation or warranty. It is the dealer’s responsibility to verify any circuit before interfacing with it using a digital multi-meter. Directed Electronics Inc. assumes no responsibility with regards to the accuracy or currency of this information. Proper installation in every case remains the responsibility of the installer. Directed Electronics Inc. assumes no liability or responsibility resulting from an improper installation, even in reliance of this information.