

## Alarm bypass on the 1999 Yukon Denali & Escalade

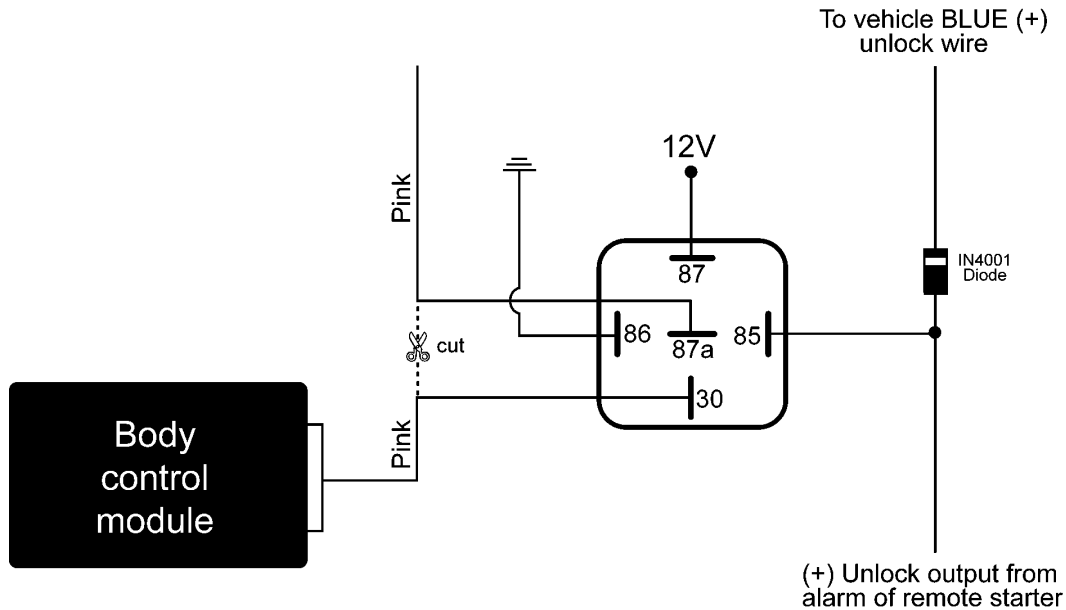

The Alarm system on the 1999 Yukon Denali & Cadillac Escalade disarms with the keyless entry remote or when the ignition switch is turned on. In the case of a remote start installation, the alarm will shut down automatically when the ignition system powers up. To shut down the alarm when unlocking the doors from any other remote, you will need to pulse the ignition wire at the **Body Control Module** located under the storage compartment in the center console. The configuration shown in this diagram will open the ignition wire at the **BCM** and simultaneously send 12 volts to the module side. This will keep it from sending 12 volts back to the rest of the ignition system and turning on the instrument cluster.

**NOTE:** The information on this sheet is provided on an "as is" basis with no representation or warranty of accuracy whatsoever. It is the sole responsibility of the installer to check and verify any circuit before connecting to it. Only a computer safe logic probe or digital multimeter should be used. VSI Vehicle Systems Information Corp. assumes absolutely no liability or responsibility whatsoever pertaining to the accuracy or currency of the information supplied. The installation in every case is the sole responsibility of the installer performing the work and VSI Vehicle Systems Information Corp. assumes no liability or responsibility whatsoever resulting from any type of installation, whether performed properly, improperly or any other way. The information supplied is a guide only.