

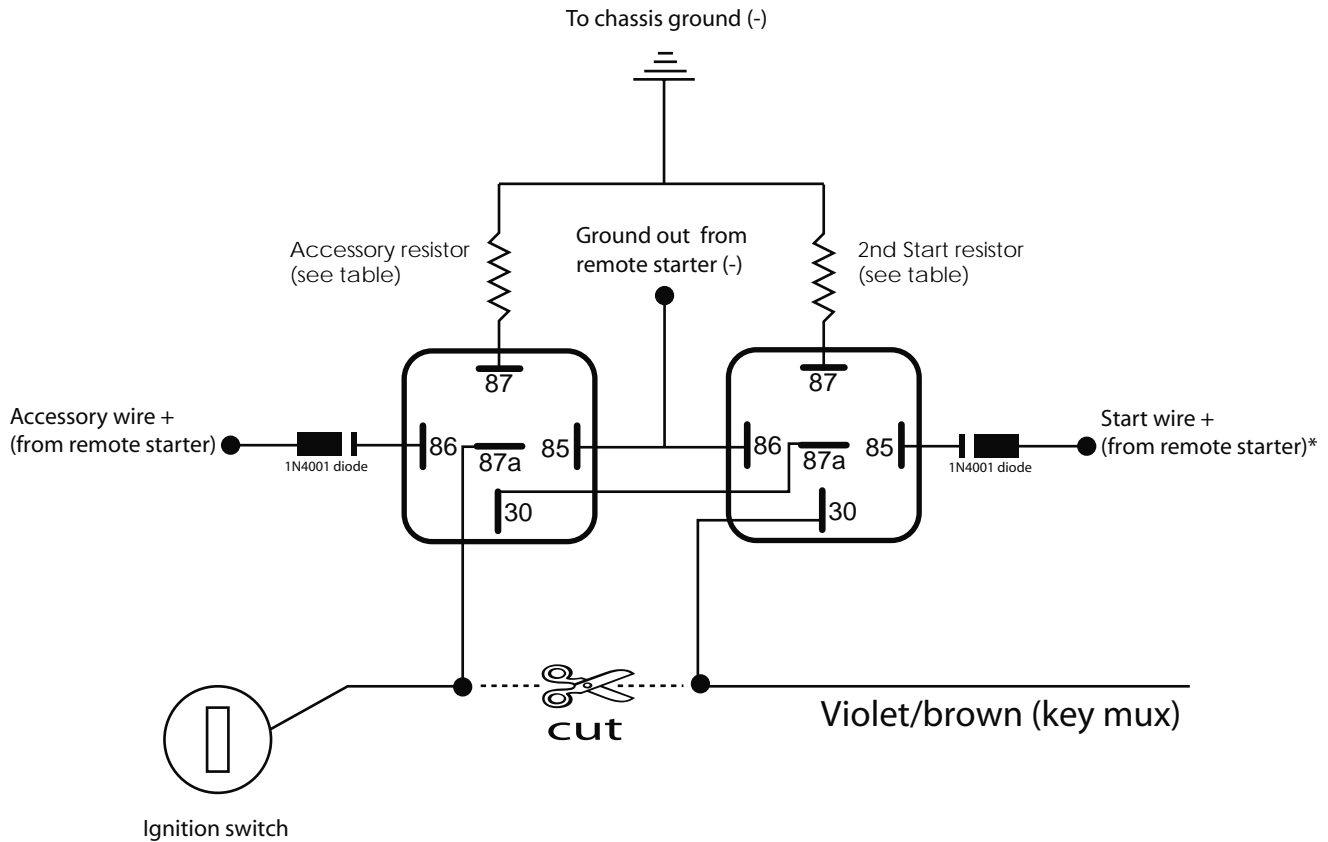

Mux wire interface for remote start on select Chrysler/Jeep vehicles 2005+



Locate the mux wire and wire in 2 relays as shown in the diagram. Locate you vehicle from the list below.

* The normal connection to the vehicle's start wire is still required.

Vehicle	Accessory resistor	2nd Start resistor
300/300c/Magnum 2005+	600 ohms	180ohms
Aspen 2007+	560 ohms	180 ohms
Pt Cruiser 2006+	600 ohms	180ohms
Caliber 2007+	600 ohms	180ohms
Charger 2006+	600 ohms	180ohms
Nitro 2007+	600 ohms	180ohms
Ram Pickup 2006+	560 ohms	180ohms
Commander 2006+	560 ohms	180ohms
Compass 2007+	560 ohms	180ohms
Grand Cherokee 2005+	560 ohms	180ohms
Patriot 2007+	560 ohms	180ohms
Wrangler 2007+	600 ohms	180ohms

NOTE: The information on this sheet is provided on an "as is" basis with no representation or warranty of accuracy whatsoever. It is the sole responsibility of the installer to check and verify any circuit before connecting to it. Only a computer safe logic probe or digital multimeter should be used. Wiremagic.com Corp. assumes absolutely no liability or responsibility whatsoever pertaining to the accuracy or currency of the information supplied. The installation in every case is the sole responsibility of the installer performing the work and Wiremagic.com Corp. assumes no liability or responsibility whatsoever resulting from any type of installation, whether performed properly, improperly or any other way. The information supplied is a guide only.