

FORD GEM WAKE UP

NORMALLY CLOSED DOOR TRIGGER

When adding keyless entry to Ford vehicles with door locks that shut down, the GEM Module must be activated before the doors will unlock. Some vehicles have Door Ajar wires that rest at ground when the door is shut. This means that the Door Ajar wire must be opened to activate the GEM module. The lock, unlock, and driver Door Ajar wires can usually be found inside the driver door or in the door boot.

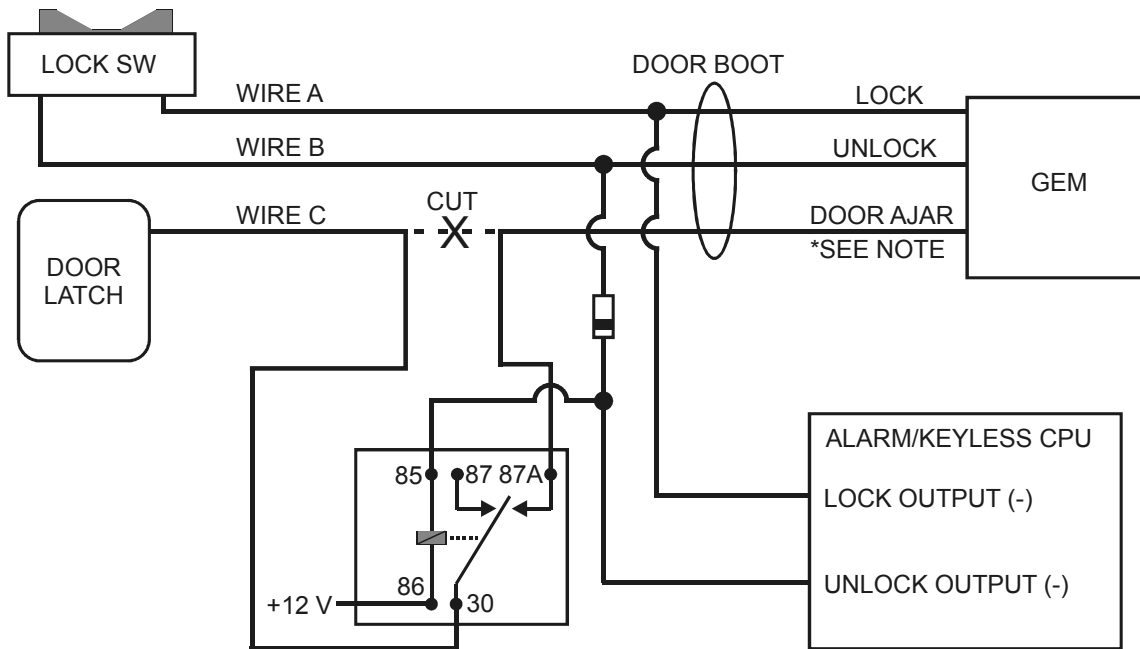

NOTE: When testing the Door Ajar wire, it will rest at ground when the door is closed and pulse to (+) 12 volt when the door opens then return to ground. This diagram will also activate the dome light upon unlock.

WIRE COLORS

VEHICLE	WIRE "A"	WIRE "B"	WIRE "C"
02 EXCURSION	WHITE/RED	BLACK/WHITE	YELLOW/BLACK*
02-03 F-SERIES SUPER DUTY	WHITE/RED	BLACK/WHITE	YELLOW/BLACK*
02-03 EXPLORER	PINK/YELLOW	PINK/LT GREEN	YELLOW/BLACK*
02-03 MOUNTAINEER	PINK/YELLOW	PINK/LT GREEN	YELLOW/BLACK*

*Also found as YELLOW/GREY

NOTE: Program the system to from single unlock pulse to double unlock pulse.

IMPORTANT! This wiring information is being provided free of charge on an "as is" basis, without any representation or warranty. It is the dealer's responsibility to verify any circuit before interfacing with it using a digital multi-meter. Directed Electronics Inc. assumes no responsibility with regards to the accuracy or currency of this information. Proper installation in every case remains the responsibility of the installer.