

Doorlocks on Jeep Liberty 2002 & up

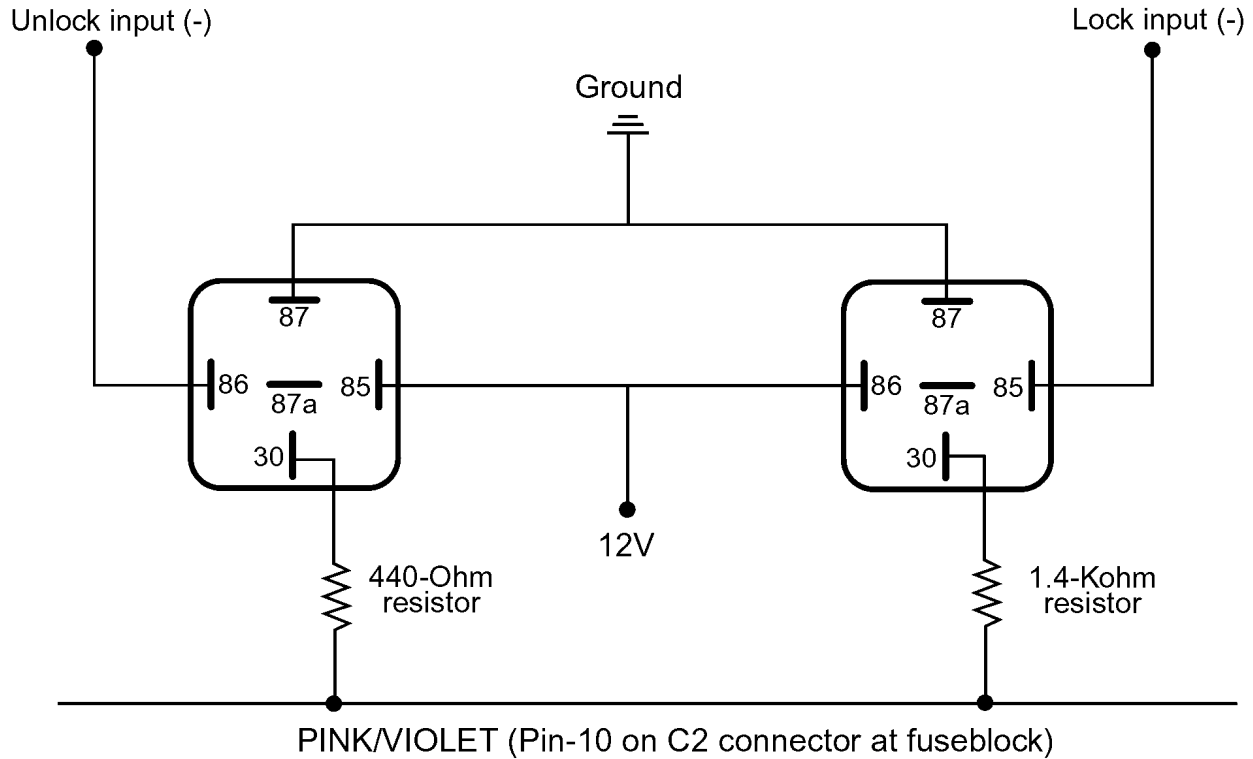

This 1-wire doorlock system requires resistors. The values indicated are the exact values from Jeep. You can go higher or lower by about 5-10% and it should still work fine. The Fuseblock is located directly below the driver's side of the dash. The lower panel is clipped in place (no screws to remove). Relays are used to provide a good ground since the transistorized doorlock outputs from some after-market systems are not sufficient.

NOTE: The information on this sheet is provided on an "as is" basis with no representation or warranty of accuracy whatsoever. It is the sole responsibility of the installer to check and verify any circuit before connecting to it. Only a computer safe logic probe or digital multimeter should be used. VSI Vehicle Systems Information Corp. assumes absolutely no liability or responsibility whatsoever pertaining to the accuracy or currency of the information supplied. The installation in every case is the sole responsibility of the installer performing the work and VSI Vehicle Systems Information Corp. assumes no liability or responsibility whatsoever resulting from any type of installation, whether performed properly, improperly or any other way. The information supplied is a guide only.