



SPECIFIC VEHICLE ALARM FITTING INSTRUCTIONS

REV. 01

www.cobra.it

MAKE	VOLVO	MOD.	XC 90*	YEAR	03 →	PETROL <input checked="" type="checkbox"/>	DIESEL <input type="checkbox"/>
------	--------------	------	---------------	------	-------------	--	---------------------------------

* Models with original equipment keyless entry system.

ALARM/SIREN POSITION	Position the compact alarms and the sirens on the support of the servobrake, in the engine compartment.
CENTRAL UNIT POSITION	Position the modular systems and the modules under the driver's side dashboard.
POWER SUPPLY	+ 30 : connect directly to the positive end of the battery. - 31 : connect directly to the car body.
IGNITION WIRE	+ 15/54 : connect to the BLUE wire, at the position nr. 9, on the fuse box, on the side of the dashboard, driver's side.
DIRECTION INDICATORS	Connect to the GREEN and GREEN/WHITE wires, in the grey connector, located on the left, under the dashboard.
ELECTRIC WINDOWS	<p>Positive control signals</p> <p>Front window, drivers side: cut the VIOLET wire, at the position nr. 4, in the 12 way grey connector, in the driver's side switches panel.</p> <p>Front window, passengers side: cut the VIOLET wire, at the position nr. 4, in the 12 way grey connector, in the driver's side switches panel.</p> <p>Rear window, drivers side: cut the GREEN/BROWN wire, at the position nr. 1, in the grey connector, marked MI 24, behind the relay holder form, under the driver's side dashboard.</p> <p>Rear window, passengers side: cut the GREEN/BROWN wire, at the position nr. 1, in the grey connector, marked M1, behind the relay holder form, under the driver's side dashboard</p>
ACTIVAT./DEACTIVATION CONTROLS	<p>Connections antitheft/vehicle</p> <p>Refer to the fitting diagram nr. 185R1.</p>
IMMOBILISATION POINT	<p>Fuel pump</p> <p>Cut the LIGHT BLUE wire, at the position nr. 7, on the MI 12 connection, behind the relay holder plate.</p>
STARTER	+ 50 : cut the BLACK/VIOLET wire coming out of the ignition key.
BONNET SWITCH	Install an additional switch on the front headlamp support plate.
DOORS SWITCH	<p>Connect to the WHITE wire of the lamp that enlighten the pedals.</p> <p>Note: the front lamp is with positive polarity. Invert the polarity with an additional relay.</p>
BOOT SWITCH	<p>Connect to the WHITE wire of the serial boot lamp.</p> <p>Note: the boot lamp is with positive polarity. Invert the polarity with an additional relay.</p>

FITTING DIAGRAM NR. 185R1

3800 serie antitheft

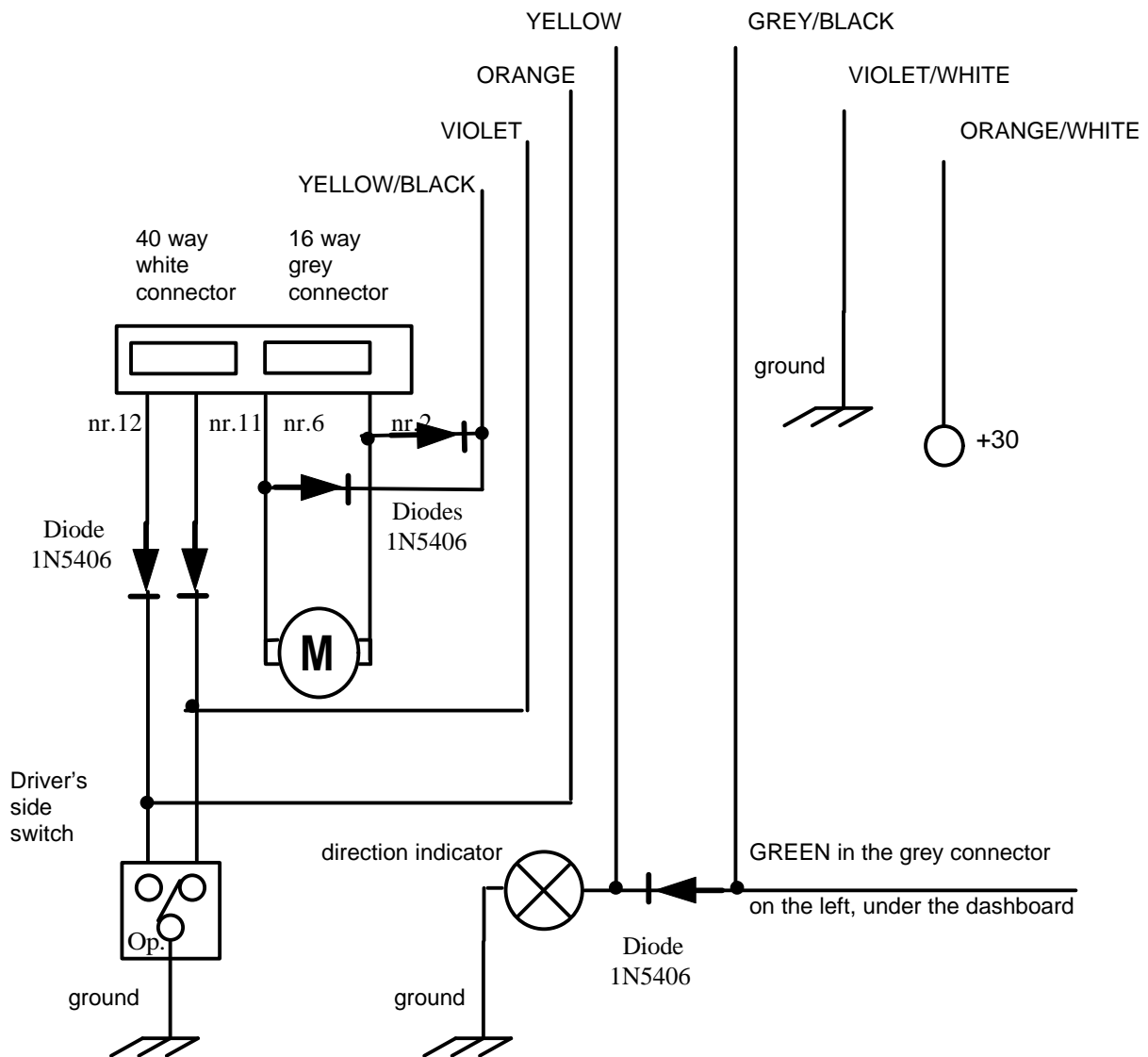

The white 30 way and grey 12 way connectors are located on the coming out of the push button panel directly inside the driver's side door.